

Rockfon® System XL T24 D™

System Description

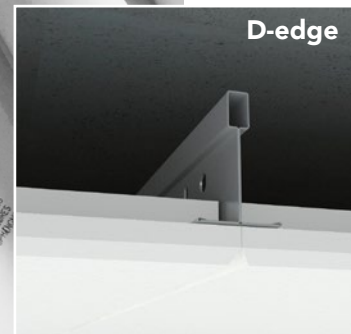
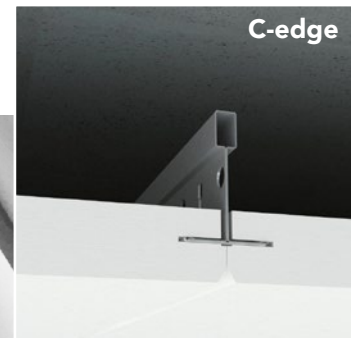

Concealed ceiling system Continuous expression

- Elegant, continuous ceiling expression
- Demountable for quick and easy access to installations
- Installed in a standard T24 full height grid
- 33% less hangers compared to other D systems

Description

Rockfon System XL T24 D is a concealed grid system that provides an elegant, continuous ceiling expression. The system is characterised by quick installation compared to traditional concealed grid systems. This is due to the low number of components and fixings. It combines the Chicago Metallic™ T24 Click 2890 grid and D edge Rockfon tiles.

When creating a ceiling using Rockfon System XL T24 D, the main runners are positioned at 1800 mm centres compared to the 1200 mm centres traditionally used. This provides time and space savings while creating a very elegant looking ceiling.

The principles of Rockfon System XL T24 D make it particularly suited for larger spaces. The system can be directly fastened to the soffit (taking into account the minimum installation depth) or suspended in different heights. 1/3 of the tiles installed in Rockfon System XL T24 D are fully demountable, the other 2/3 can be demounted by disengaging them from the main runner.

With the Rockfon System XL T24 D you use 33% less hangers which makes it far quicker to install.

The system includes main runners, cross tees (in several lengths), wall angles, hangers and several accessories.

Rockfon ceiling tiles with D-edge in dimension 600 x 600 mm can be installed in Rockfon System XL T24 D. Cross tees have a specially developed "click", ensuring quick and easy assembly and demounting.

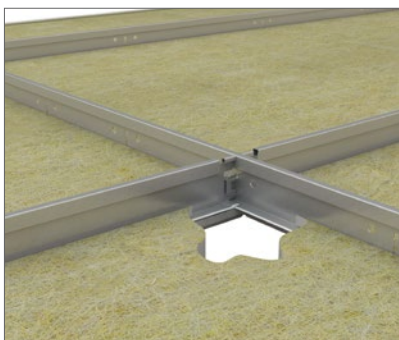
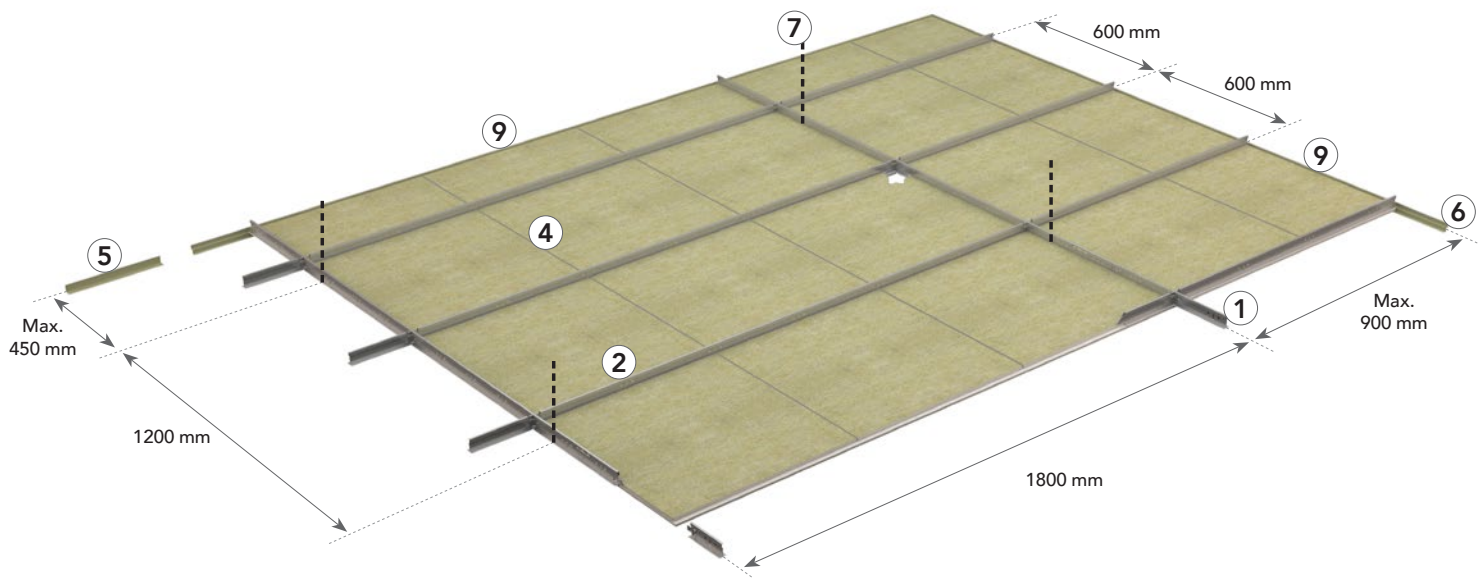

Click system providing quick and easy mounting and de-mounting.

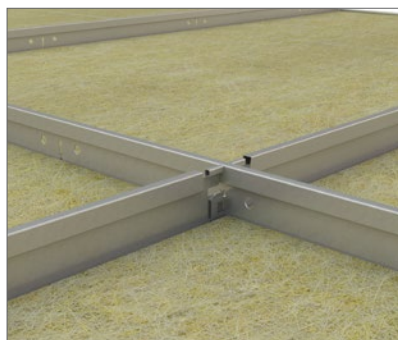

38 mm full height main runners and cross tees for stability and easy service integration.

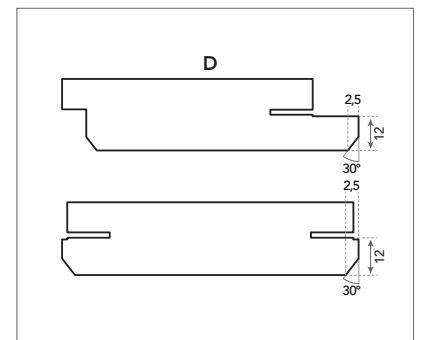

D edge detail comprising D edge on two sides with C edge on two adjacent sides

System components and consumption guide

Tile	Chicago Metallic T24 Click 2890				Wall angles		Accessories			
	1	2	3	4	5	6	7	8	9	
D-edge	Main runner T24 Click/Hook 3600	Cross tee T24 Click 1800	Spacer bars	Stiffening profile	Perimeter wall angle trim 24 x 24	W shadow moulding wall angle	Hanger	Direct fixing bracket	Wall clip	
Dimension (mm)	Consumption/m ²									
600 x 600	2.78 pcs/m ²	0.56 lm/m ²	1.67 lm/m ²	-	2.22 lm/m ² *	1)	1)	0.46 pcs/m ²	0.46 pcs/m ²	1)

1) Consumption depends on room size.

* Optional.

Tile - D Edge



Chicago Metallic T24 Click 2890

1. Main runner T24 Click/Hook 3600



2. Cross tee T24 Click 1800



Wall angles

5. Perimeter wall angle trim 24 x 24



3. Spacer bar

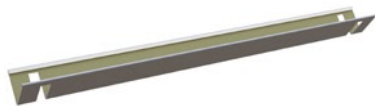

4. Stiffening profile



6. W shadow moulding wall angle



Accessories

7. Hanger



8. Direct fixing bracket



9. Wall clip



Performance



System load bearing capacity

		Max. Load (kg/m ²)	
Hanger distance (mm)	Dimensions (mm)	Max. 2.5 mm deflection	Max. 4.0 mm deflection
1200	600 x 600	3.3	5.7

The system's load capacity is determined from a max. deflection of the individual components corresponding to 1/500 of the span or the cumulative deflection of all structural components which does not exceed 2.5 or 4 mm. The load bearing capacity is given as regularly distributed load in kg / m², the weight of the tile is not included.



Corrosion resistance

Class B (EN13964)



Demountability

1/3 of the tiles installed in Rockfon System XL T24 D are fully demountable, the other 2/3 can be demounted by disengaging them from the main runner.



Fire resistance

Some Rockfon ceiling systems have been tested and classified in accordance with European norm EN 13501-2 and/or national norms. Please contact Rockfon.

Compatible Tiles Overview

All Rockfon D edge tiles available in dimensions mentioned below can be installed in Rockfon System XL T24 D.

		Dimensions (mm)
Tiles	Thickness (mm)	600 x 600
Rockfon Blanka®	20	•
Rockfon Blanka® dB	30-50	•

Grid Installation

Grid layout and hanger location

Rockfon D edge tiles can be installed in Rockfon System XL T24 D.

Some layout options are shown below depending on the size of the tile.

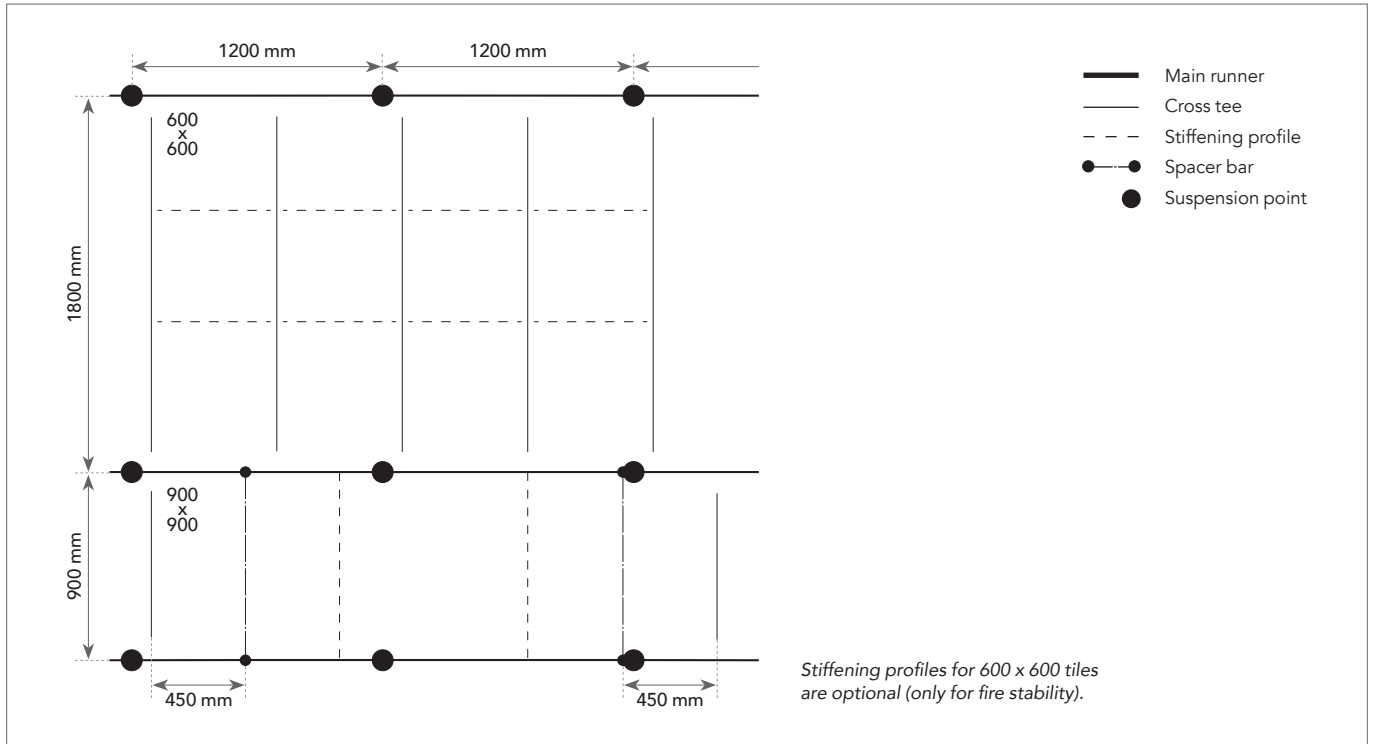

Installation requirements

During and after the grid installation, it is important to check that the T profiles are perfectly aligned horizontally. A maximum level difference of +/- 1 mm is recommended between the profiles. This tolerance is valid for all directions.

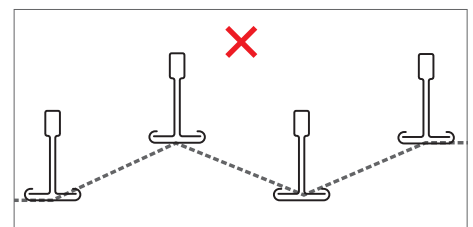
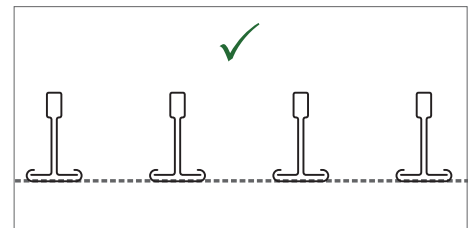

It is also important to check the squareness of the angles between the main runners and cross tees. This can be done easily by comparing the measurements of the two diagonals. See recommended tolerances on the drawing below.

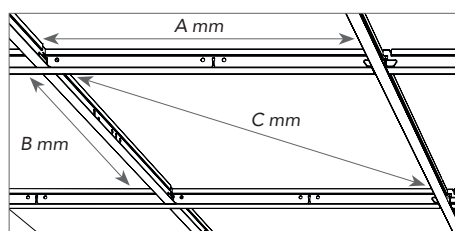

Dimensions (A x B)	Diagonal (C)	Tolerance
mm		
600 x 600	1867.1	+/- 1,0

Tile Installation

600 x 600

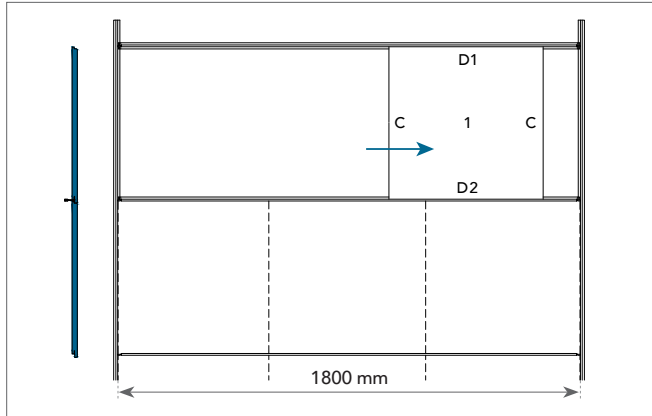

900 x 900

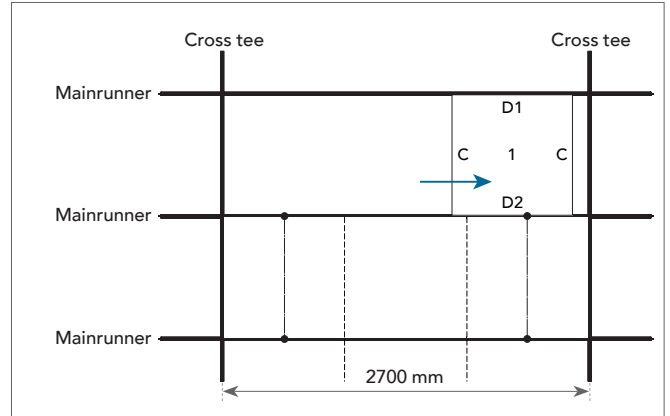

Tile 1. The installation starts with the first Rockfon tile placed between two cross tees, the C-edge is locked in the main runner.

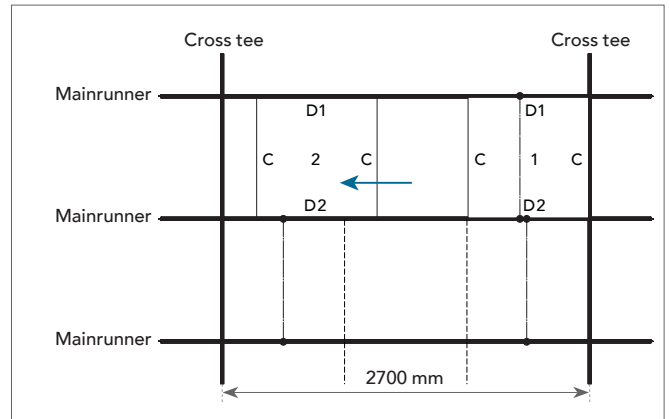
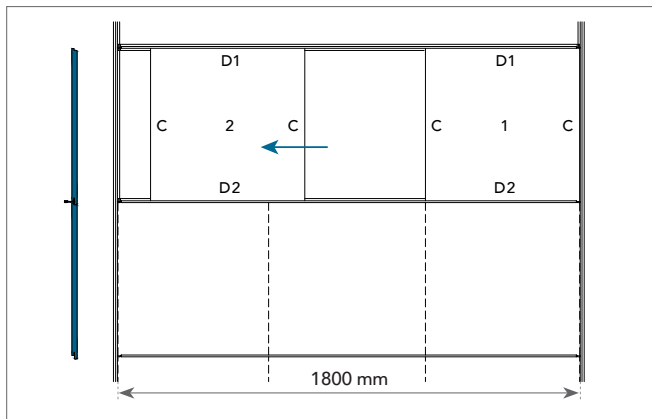

Tile 2. Same principle for installing the next tile on the opposite side.

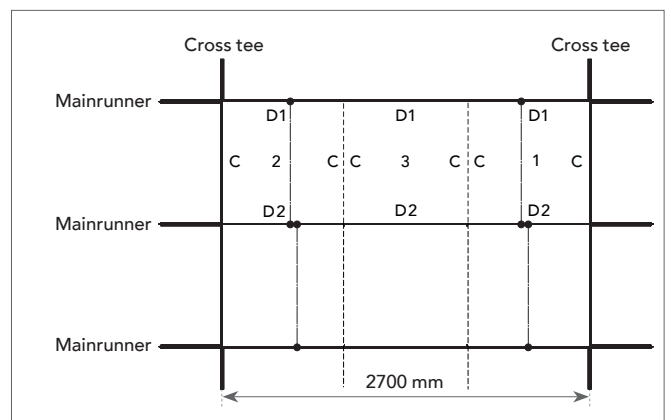
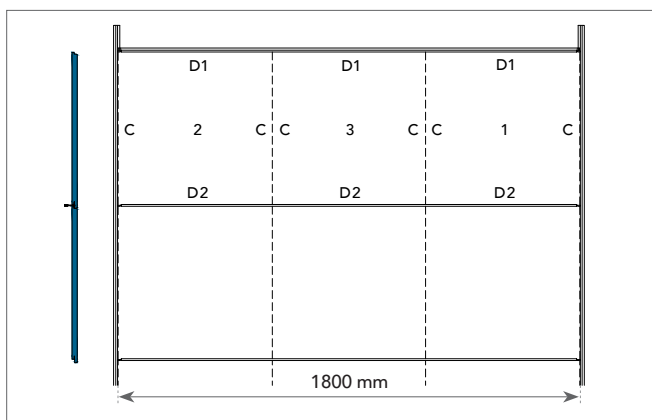

Tile 3. The last tile fits between the two tiles, installed in the centre. This tile is fully demountable. At the wall an edge spring or edge wedge can be installed.

Demounting

The middle tile 3 is, within a finished assembly, directly demountable. For demounting, press carefully in the middle of this tile, lift it up and demount. Then, the two other tiles can be removed by pulling them out of the main runner and then lift them out.

Minimum installation depth (mm)

Tiles installed in Rockfon System XL T24 D are fully demountable.

The installation depth is defined as the distance from the underside of the tile to the underside of the substrate, where the hangers are fixed. D represents the minimum installation depth that allows for easy tile installation and demounting.

Tile thickness	Dimensions	D
mm		
20-25	600 x 600	100
30	600 x 600	112
40	600 x 600	112
50	600 x 600	112

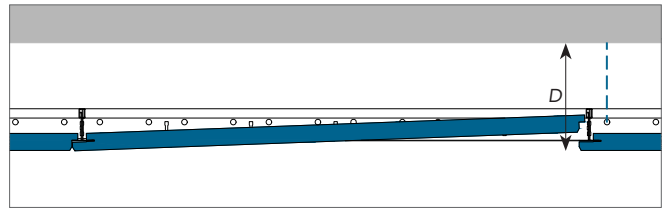

Perimeter Finish Options

Below are examples of perimeter finishing. Further details can be found on www.rockfon.co.uk

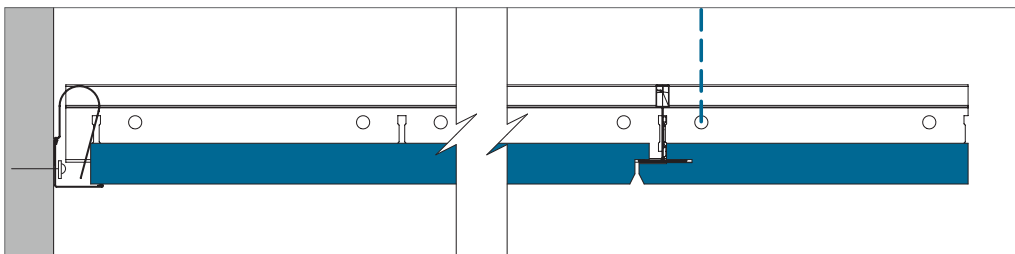

Perimeter finish with wall angle trim.

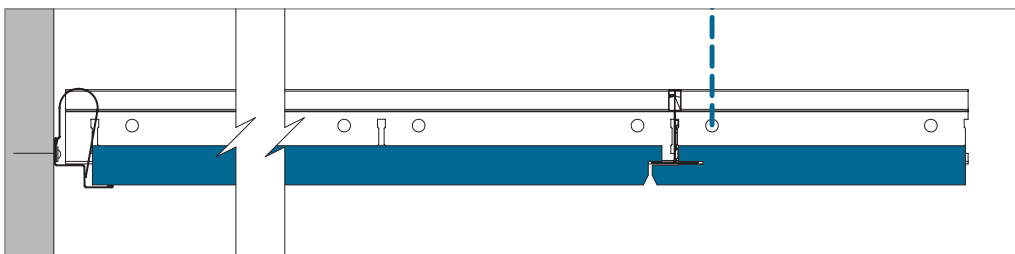

Perimeter finish with shadow wall angle trim.

Service integration

Rockfon ceiling tiles are easy to cut and therefore it is very easy to integrate service installations in our ceiling tiles. Cutouts can be made with a simple utility knife.

When the ceiling system is load bearing, Rockfon recommends using a yoke or extra support arms that spreads the transfers the weight of the service to the grid. The size of the yoke should not be bigger than the module size 600 x 600 and the use of extra hangers to overcome deflection in the ceiling system is strongly recommended. When using support arms to spread the weight of the installation, we recommend spanning a maximum 600 mm and the use of extra hangers to overcome deflection in the ceiling system.

When installing a modular lighting fixture in Rockfon system XL T24 D please be aware of the special edge design and module size of this solution. Because of the asymmetric ceiling tile design, a special type of luminaire should be chosen in order to create an aesthetically pleasing and well leveled ceiling surface. The actual size of the ceiling tile is nearly its module size and the front surface of the ceiling tile sits approx. 12 mm below the front of the T-grid. For more information, please contact Rockfon.

Planning

A thorough planning and installation scheduling of the project will result in less re-work and less ceiling tile damages. Rockfon recommends discussing the installation planning thoroughly and well in advance with other installers that have to work in or near the suspended ceiling. By doing so damaged ceiling tiles and dirty spots on the finished ceiling surface can be avoided, which reduces project costs.

Overview load bearing capacity

	Weight of installations		
	< 0.25 kg/pcs	0.25 ≥ 3.0 kg/pcs	> 3.0 kg/pcs
Small service integration; Spot- or downlight, speaker, ventilation etc.	Drawing A	Drawing B	Independently suspend
Large service integration; Downlight, speaker, ventilation, etc.	Drawing A	Drawing B	Independently suspend
Modular lighting- or ventilation fixture	Drawing C; System load bearing capacity (if evenly distributed over grid in kg/m²)		Independently suspend

When installing services in Rockfon System XL T24 D you should always follow local building regulations if more strict than the load bearing capacity constraints Rockfon recommends in the above table.

Contact your local Rockfon technical service for more information on suitable lighting fixtures, accessories and the availability of CAD drawings for the different services integrated in Rockfon System XL T24 D. Special solutions with integrated services are, if available, shown on page 11 of this document in the Tools section.

Drawing A

The integration of a spotlight, smoke detector, speaker, etc. (weighing < 0.25 kg/pcs). Rockfon recommends installing spotlights and downlights centralized in the tile.

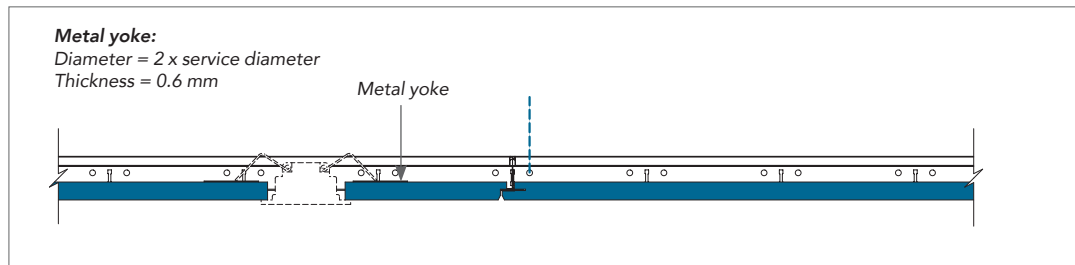

Drawing B

The integration of a downlight, spotlight, smoke detector, loud speaker, etc. (weighing $0.25 \geq 3.0$ kg/pcs). Use of an appropriate yoke to spread the load to the grid (as shown in the detail) or use of support arms to spread the load to the grid system is strongly recommended. The use of additional hangers to avoid excess deflection and a centralised installation of the lighting in the tile is strongly recommended.

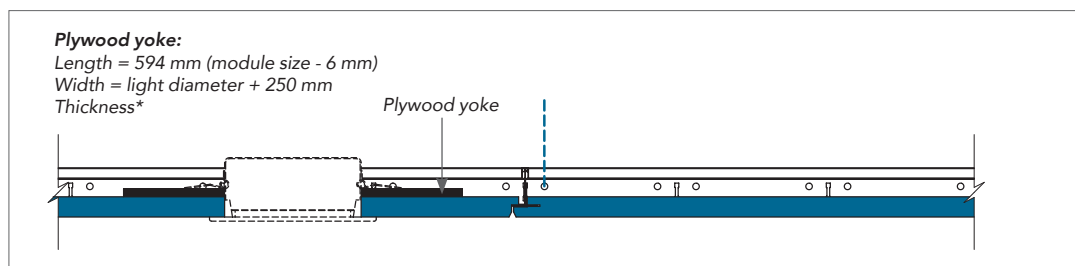

* The thickness of the plywood or metal yoke needs to be adapted in function of the weight, size and position of your service integration (e.g. downlight or speaker). The Plywood or metal yoke itself may not deflect after installing your service integration.

Drawing C

The integration of a modular luminaire or air vent (evenly distributed over grid), weighing max. the system loading capacity. If the load capacity of the system is likely to be exceeded it is strongly recommended to suspend the service independently. Alternatively use services equipped with supporting arms on minimum two opposite sides to transfer the weight of the service to the top of the bulb of the grid. This is safer and reduces the likelihood of cross tee rotation.

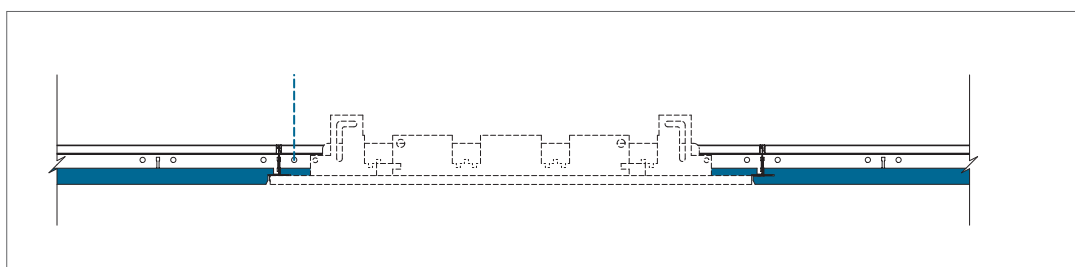

Specific solution

Flat hanger

Flat hanger brackets are used on cross tees in combination with adjustable hangers to facilitate the installation of D edge tiles with thickness greater than 35 mm.

This solution can also be used for additional weight from service installations or similar.



Grid layout and hanger location

Rockfon Activity and dB D edge tiles can be installed in Rockfon System XL T24 D. To prevent inappropriate deflection of the grid, an extra hanger on the cross tees should be installed as shown below.

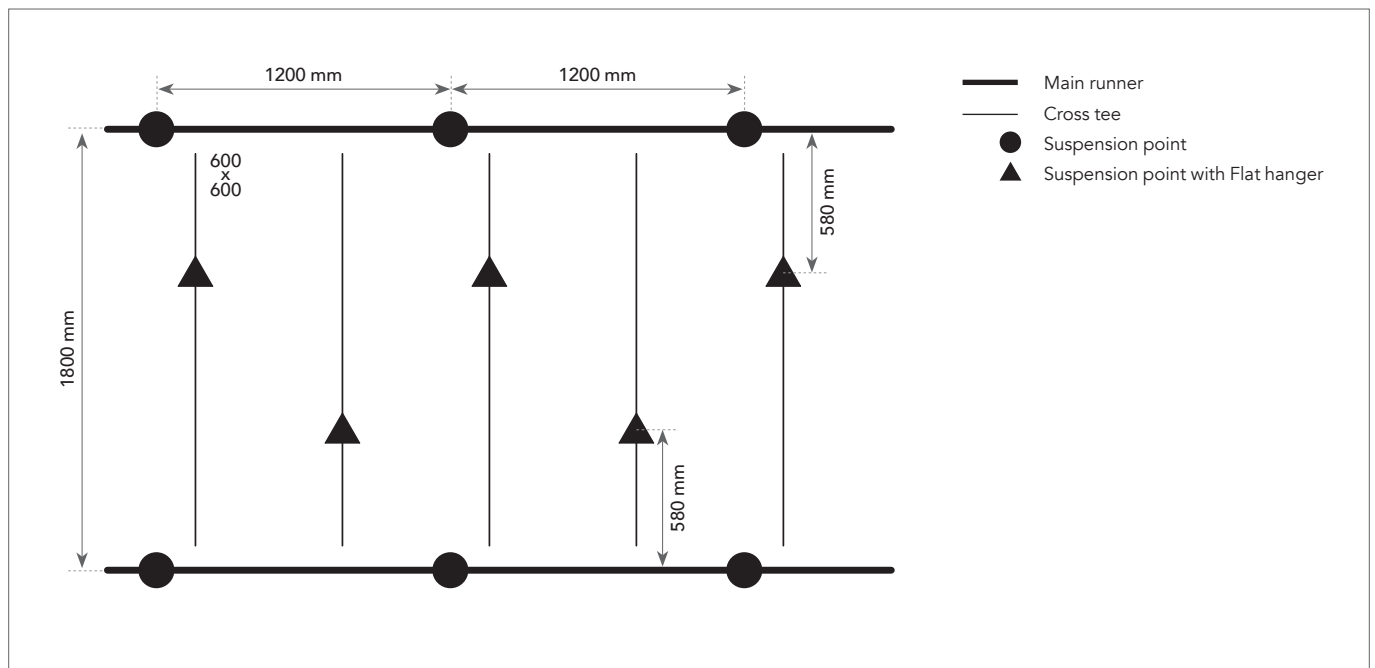

General installation recommendations

Junction between ceiling and wall or other vertical surface

The perimeter trim should be fastened to the vertical surfaces at the required level, using the appropriate fixings every 300-450 mm. Ensure that butt joints between adjoining lengths of trim are neat and that the trim is free from kinks and that it remains true and level. Use as long a length of trim as possible for an optimal aesthetic look. The minimum recommended cut length is 300 mm.

Timber trims, timber shadow battens and metal

Shadow mouldings should not be used with fire resisting/protecting ceilings.

Junction between ceiling and curved vertical surface

The use of a preformed curved perimeter trim is the most appropriate method. We can provide details of curved perimeter trims on request.

Corners

Perimeter trims should be neatly mitred at all corner joints. Overlap mitres are acceptable for metal trims on internal corner joints, unless specified otherwise.

Suspension grid

Unless specified otherwise, the ceiling system should be built from the centre of the room outwards. The hangers should be fastened to the main runner at every 1200 mm centres, or less with a greater load. For an optimal finish, we recommend that the perimeter tile has a width greater than 200 mm.

Main runners should be positioned at 1800 mm centres for 600 x 600 mm. For 900 x 900 mm module size, main runners are installed at 900 mm centres.

For proper grid installation, ensure the T profiles are perfectly aligned, horizontally and diagonals of modules are equal (see requirements and tolerances on page 5). Main runner joints should be staggered and there should be a hanger positioned within 150 mm of the fire expansion element/cut-out and within 450 mm of the end of the main runner where it terminates at a perimeter.

Additional hangers may be necessary to support the weight of ceiling services. When using direct hangers, a fixing nail should be used to lock the hanger on to the bulb of the main runner.

Tiles

It is recommended to use clean nitrile or PU coated gloves when mounting Rockfon tiles in order to avoid finger prints and pollution of the surface.

For an optimised work environment, we recommend installers always observe common work practices and follow the installation advice as shown on our packaging.

Cutting is made easily with a sharp knife. All offcuts and holes must be treated according to local Building Regulations.

Note! Certain smooth matt surfaces are directional. To ensure consistency of the finished ceiling, it is important that all tiles are mounted in one direction, as indicated by the arrow printed on the back of each tile.

Tools

Rockfon has developed specific tools that are available on www.rockfon.co.uk



Visit our online CAD Library or BIM portal to assist you in your project design.

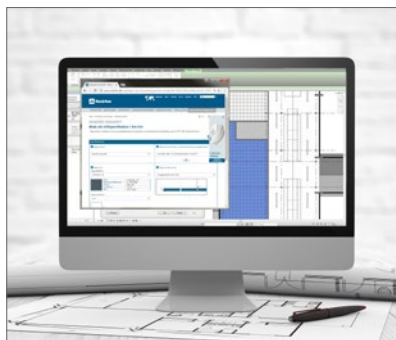



Generate specification texts for our products on our website.



Explore our vast library of reference projects on our website.

Rockfon® is a registered trademark
of the ROCKWOOL Group.

 twitter.com/RockfonUK

 linkedin.com/company/Rockfon-uk/

 instagram.com/Rockfon_official/

 youtube.com/RockfonUK

09/2019 | All colour codes mentioned are based on the NCS - Natural Colour System™ property of and used on license from NCS Colour AB, Stockholm 2012 or the RAL colour standard. Subject to alterations in range and product technology without prior notice. Rockfon accepts no responsibility for printing errors.



Rockfon
ROCKWOOL Limited T/A ROCKFON
14th Floor, Chiswick Tower, 389 Chiswick High Road,
London W4 4AL
Tel: +44 (0) 208 222 7457
Fax: +44 (0)20 8222 7458
www.rockfon.co.uk